

THERMOTITE® 800C

INSULATED ROLLING STEEL DOORS



INSULATED ROLLING STEEL DOORS CUT YOUR TOTAL ENERGY COST

The Wayne Dalton ThermoTite® 800C Insulated Rolling Service Door is designed to meet the tough requirements of virtually any commercial or industrial application, with the added advantage of energy efficiency. The ThermoTite® 800C offers flexibility in substrate materials with choices of galvanized or primed steel, stainless steel, or aluminum.

Color options range from our four standard factory-finish colors to a full range of 197 RAL powder coat choices. Foamed-in-place polyurethane insulation in each slat promotes energy savings and building comfort.

*Wayne Dalton uses a calculated door section R-value for our insulated doors

- » SIZES UP TO 42' WIDE AND 30' HIGH
- » INSULATION R-VALUE* = 7.7
- » 22-GAUGE STEEL
- » FLAT 3" INSULATED SLAT
- » WIND LOAD UP TO 55 PSF

THERMOTITE® 800C

STANDARD FEATURES OVERVIEW

THERMAL EFFICIENCY

R-VALUE*	7.7
U-VALUE	0.13

CONSTRUCTION

MAX WIDTH	42' (12802 mm)
MAX HEIGHT	30' (9144 mm)
MOUNTING	Face mount; between jambs
OPERATION	Chain hoist; motor recommended on door sizes where door weight exceeds hoist effort†
CURTAIN	3" foamed-in-place polyurethane insulated galvanized steel flat slats (#34 profile), primed and painted gray, white, beige or brown; 22-gauge steel front / 24-gauge steel backer with alternating endlocks.
LOCKING	Chain holder, suitable for padlocking, on chain operated doors.
BOTTOM BAR	Galvanized steel double angle with weatherseal and insulation.
GUIDES	Three angle steel; factory-painted black.
BRACKETS	1/4" steel plates with permanently sealed ball bearing, factory-painted black.
COUNTERBALANCE	Steel pipe, painted factory black, of adequate size. Oil tempered, 20,000 cycle helical springs.
HOOD	24-gauge galvanized steel round hood with internal weatherstrip; primed and painted gray, white, beige or brown.
WIND LOAD	+/- 20 psf standard
WARRANTY	Two (2) Years

†Reference door chart on website or contact plant for more information.

OPTIONS

- Vision slats/panels
- Safety edges
- Drop stop device
- Exhaust ports
- Sloping bottom bars
- Powder coated
- Motor operation
- Cable reels
- Mullions
- Thru-wall operation
- Stainless steel or aluminum finish
- 18 and 20-gauge front slats

IECC AIR INFILTRATION PACKAGE OPTION:

- Guide cover and cap
- Dual brush guide seal
- Lintel seal
- Bottom weatherseal



*Wayne Dalton uses a calculated door section R-value for our insulated doors

Popular in both interior and exterior applications, the Wayne Dalton ThermoTite® 800C Insulated Rolling Service Door features a galvanized, pre-painted curtain of 22-gauge steel.

ThermoTite® 800C doors are designed to withstand wind loads of up to 20 PSF standard. Optional wind load ratings of up to 55 PSF is available to meet Florida and Dade County wind load requirements.

MATERIALS AND CONSTRUCTION

The ThermoTite® 800C features a strong double-angle bottom bar that reinforces the lower edge of the curtain against wind pressure and permits varied lock, astragal, and safety edge options. This bottom bar is designed for easy installation and does not require fasteners protruding into the guide openings, so the bottom bar does not interfere with door operation.

The counterbalance assembly consists of a spring barrel which serves as load-carrying beam. It encases the counterbalance mechanism and provides the axis around which the curtain coils. If required, barrel rings of malleable iron or stamped steel may be provided to assure proper counterbalance installation. Oil-tempered, torsion-type counterbalance springs are wound from heat-treated steel, providing accuracy in balancing the door. Barrel plugs connect the ends of the springs to the barrel and tension rod. A tension rod of steel shafting holds the fixed ends of the springs and carries torsion load of spring counterbalance.

The spring tension adjusting wheel is normally mounted outside the bracket on the end of tension rod. An inside adjusting wheel for tight side-room applications is available in limited sizes.



ROLLING STEEL



COLOR OPTIONS

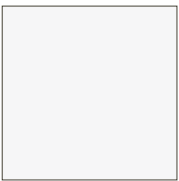

White

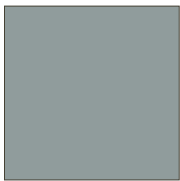

Gray

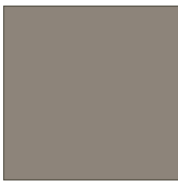

Beige



Brown

SLAT PROFILE

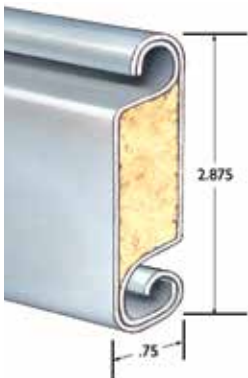

STANDARD WEATHERSEAL APPLICATIONS

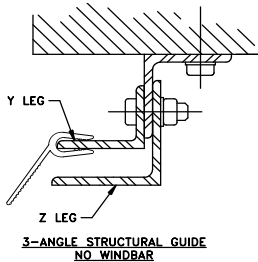

To close space between curtain and guides at jambs, flexible strip on guides contacts flat surface of curtain.



Bottom bar with weatherseal

GENERAL OPERATING CLEARANCES

WIDTH A	OPENING HEIGHT																				
	10'0"			10'0" TO 11'0"			11'0" TO 13'6"			13'6" TO 17'6"			13'6" TO 19'0"			17'6" TO 22'0"			19'0" TO 22'0"		
	X & Y	R	L	X & Y	R	L	X & Y	R	L	X & Y	R	L	X & Y	R	L	X & Y	R	L			
FACE MOUNTING																					
CHAIN HOIST OPERATED																					
TO 24'0"	18-1/2"	9 1/16"	7 1/16"	20"	9 1/16"	7 1/16"	22"	9 1/16"	7 1/16"												
TO 16'0"										24"	9 1/16"	7 1/16"				26"	9 1/16"	7 1/16"			
16'0" TO 24'0"													24"	9 1/16"	7 1/16"			26"	9 1/16"	7 1/16"	
MOTOR OPERATED																					
TO 24'0"	18-1/2"	9 1/16"	7 1/16"	20"	9 1/16"	7 1/16"	22"	9 1/16"	7 1/16"												
TO 16'0"										24"	9 1/16"	7 1/16"				26"	9 1/16"	7 1/16"			
16'0" TO 24'0"													24"	9 1/16"	7 1/16"			26"	9 1/16"	7 1/16"	

NOTE: Dimensions are for general reference only and not for construction purposes.

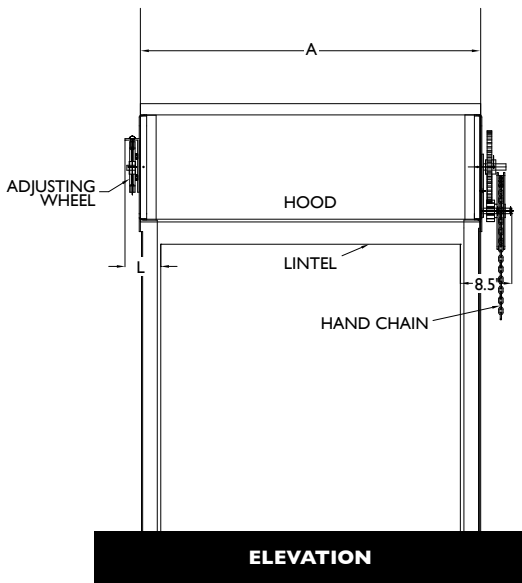

CHAIN HOIST OPERATION

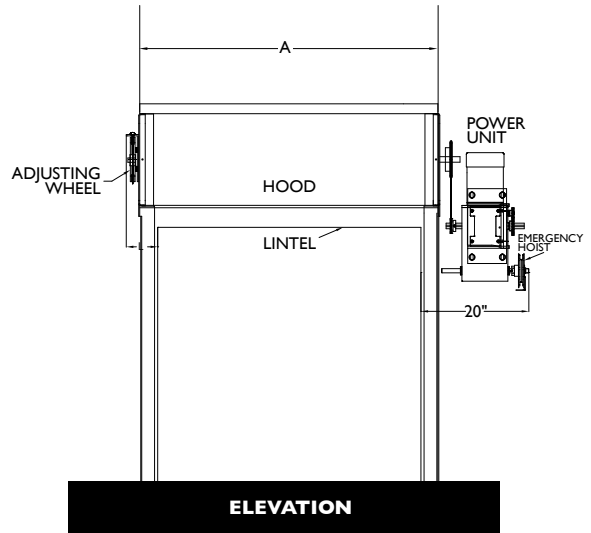

WALL MOUNTED POWER UNIT

Architect Resource Center

Go to wayne-dalton.com/commercial and click on the Architect Resource Center. Here you will quickly find all of the specifications, drawings and documents you need to complete your project.



DISTRIBUTED BY:

2501 S. State Hwy 121 Bus., Ste 200
Lewisville, TX 75067

wayne-dalton.com



©2016 Wayne Dalton, a division of Overhead Door Corporation. Consistent with our policy of continuing product improvement, we reserve the right to change product specifications without notice or obligation. Item 333068 1.5M 06/16 JAR